

## TopRoller Chain



The Top Roller chain places items on top of continuously running top roller of the chain and they can be freely conveyed regardless of direction or speed. You can choose steel or plastic resin as a roller's material according to applications.

- Advantages of Steel Roller Type: higher max. allowable Load and approval working temperature(-10 °C~150 °C)
- Advantages of Plastic Resin Roller Type: light weight, less noise

### Standardized Specification of Top Roller

Type of Chain		Roller Material of Basic Chain	Top Roller Material	Variations of Base Chain
Single Pitch Type		Steel	Steel	Stainless Steel, Nickel-plated, Zinc galvanizing, Chromium plating series
Double Pitch Type	S-Roller	Steel	Steel & Plastic	
	R-Roller	Steel & Plastic	Steel & Plastic	

### Designation of Top Roller Chain

**DBC 2040 S-TR-P-2L-SS-P**

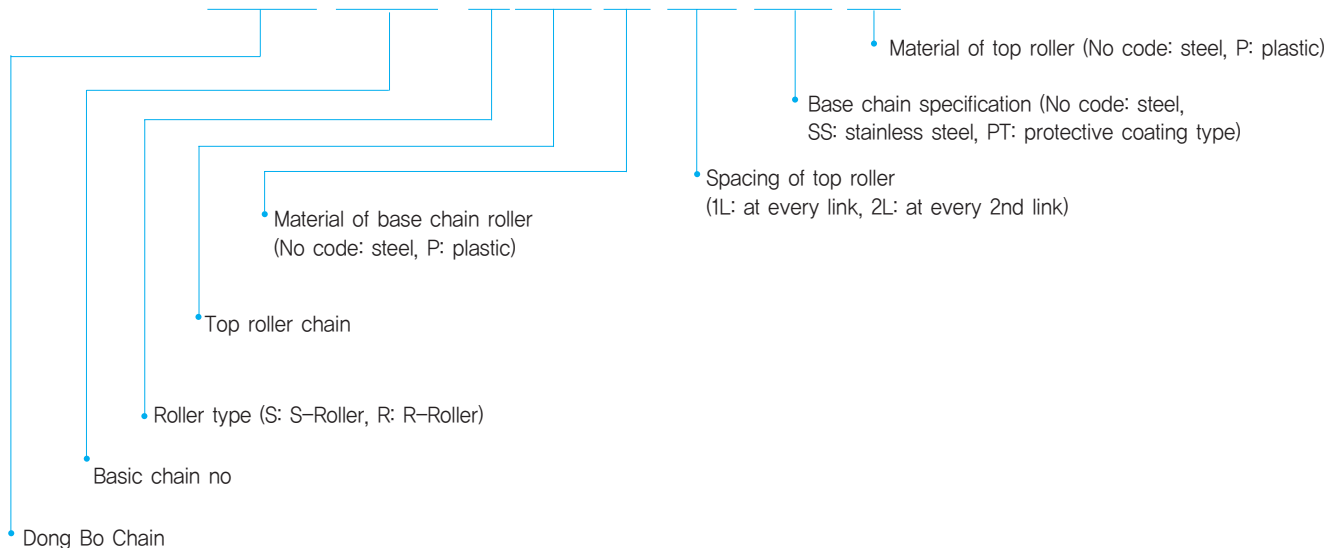



# TopRoller Chain

## Single Pitch Top Roller Chain



### Single strand

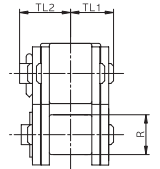
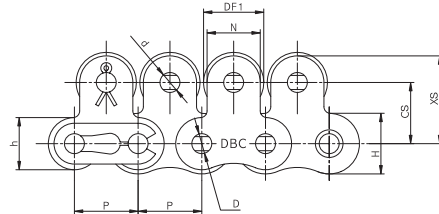
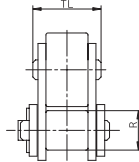
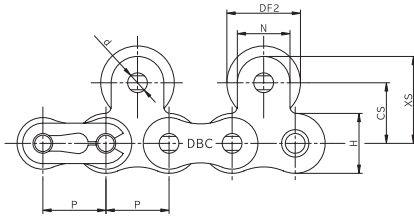
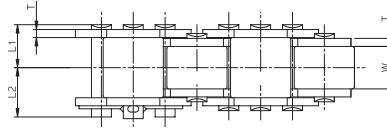
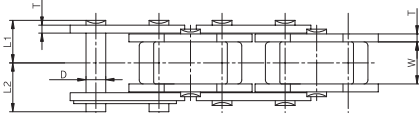

2L Type (at every 2nd Link spacing)

EL Type (at every link spacing)

unit : mm

Dong Bo CHAIN NO.	Pitch P	Inner Width W	Roller Dia R	Pin			Plate		Approx Weigth (kg/m)			
				D	L1	L2	H	T	Steel Roller Series		Plastic TopRoller Series	
									EL	2L	EL	2L
<b>DBC 40 TR</b>	12.70	7.95	7.94	3.97	8.25	9.95	12.0	1.5	1.83	1.41	0.92	0.85
<b>DBC 50 TR</b>	15.875	9.53	10.16	5.09	10.30	12.00	15.0	2.0	2.39	2.18	1.56	1.38
<b>DBC 60 TR</b>	19.05	12.70	11.91	5.96	12.85	14.75	18.1	2.4	3.60	3.18	2.30	2.03
<b>DBC 80 TR</b>	25.40	15.88	15.88	7.93	16.25	19.25	24.1	3.2	6.09	5.27	3.90	3.44
<b>DBC 100 TR</b>	31.75	19.05	19.05	9.54	19.75	22.85	30.1	4.0	9.30	8.85	6.06	5.41

unit : mm

Dong Bo CHAIN NO.	Attachment Dimensions								
	DF1	DF2	CS	N	XS	TL	TL1	TL2	d
<b>DBC 40 TR</b>	11.0	15.88	12.7	9.5	17.45	13.2	8.25	9.65	3.97
<b>DBC 50 TR</b>	15.0	19.05	15.9	12.7	22.25	16.2	10.30	11.90	5.09
<b>DBC 60 TR</b>	18.0	22.23	18.3	15.9	26.25	20.6	12.85	15.25	5.96
<b>DBC 80 TR</b>	24.0	28.58	24.6	19.1	34.15	25.7	16.25	19.25	7.93
<b>DBC 100 TR</b>	30.0	39.69	31.8	25.4	44.50	31.0	19.75	22.85	9.54

\* 'Spring clip type connecting link' is applied for DBC 40~60TR 3rd 'cotter Type' for 80TR and larger



## TopRoller Chain

### Single Pitch Top Roller Chain

#### Double strands

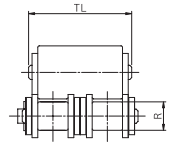
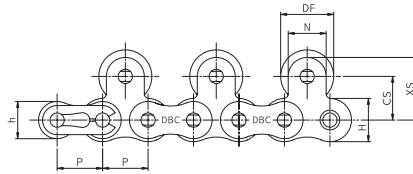
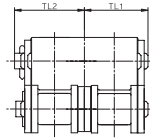
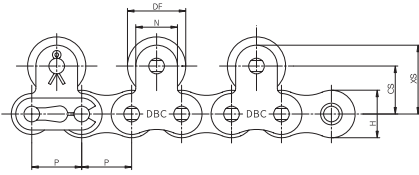
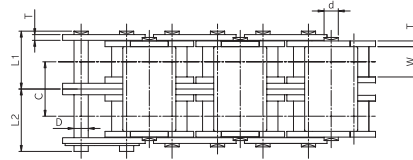
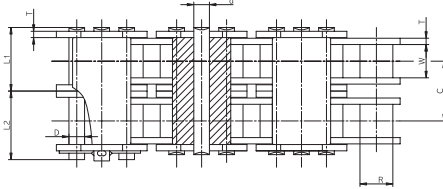

Outer Link Top Roller Installation

Inner Link Top Roller Installation

unit : mm

Dong Bo CHAIN NO.	Pitch P	Inner Width W	Roller Dia R	Transverse Pitch C	Pin			Plate		Attachment Dimensions							
					D	L1	L2	H	T	DF	CS	XS	N	TL	TL1	TL2	d
<b>DBC 40-2 TR</b>	12.70	7.95	7.94	14.4	3.97	15.45	17.15	12.0	1.5	15.88	12.7	17.45	9.5	28.3	15.45	16.95	3.97
<b>DBC 50-2 TR</b>	15.875	9.53	10.16	18.1	5.09	19.35	21.15	15.0	2.0	19.05	15.9	22.25	12.7	34.3	19.35	21.15	5.09
<b>DBC 60-2 TR</b>	19.05	12.70	11.91	22.8	5.96	24.25	26.25	18.1	2.4	22.23	18.3	26.25	15.9	43.4	24.25	26.75	5.96
<b>DBC 80-2 TR</b>	25.40	15.88	15.88	29.3	7.93	30.9	33.9	24.1	3.2	28.58	24.6	34.15	19.1	55.0	30.9	33.9	7.93
<b>DBC100-2 TR</b>	31.75	19.05	19.05	35.8	9.54	37.7	40.8	30.1	4.0	39.69	31.8	44.50	25.4	66.9	37.7	40.8	9.54

#### Derailing Prevention Type

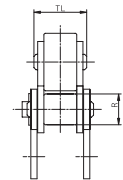
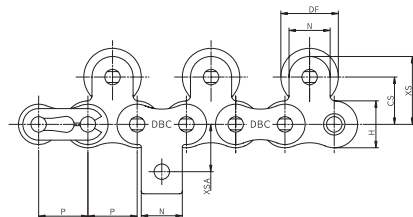
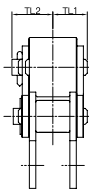
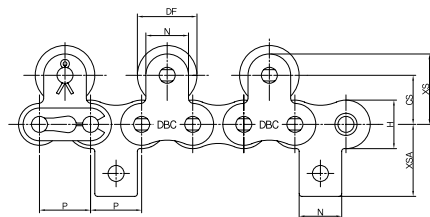
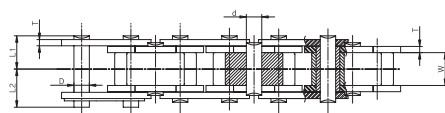
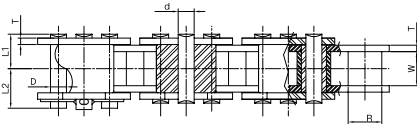

Outer Link Top Roller Installation

Inner Link Top Roller Installation

단위 : mm

Dong Bo CHAIN NO.	Pitch P	Inner Width W	Roller Dia R	Pin			Plate		Attachment Dimensions								
				D	L1	L2	H	T	DF	CS	N	XS	TL1	TL2	TL	d	XSA
<b>DBC 40 TR-TG</b>	12.70	7.95	7.94	3.97	8.25	9.95	12.0	1.5	15.88	12.7	9.5	17.45	8.25	9.65	13.2	3.97	17.4
<b>DBC 50 TR-TG</b>	15.875	9.53	10.16	5.09	10.3	12.0	15.0	2.0	19.05	15.9	12.7	22.25	10.3	11.9	16.2	5.09	23.05
<b>DBC 60 TR-TG</b>	19.05	12.70	11.91	5.96	12.85	14.75	18.1	3.2	22.23	18.3	15.9	26.25	12.85	15.25	20.6	5.96	26.85
<b>DBC 80 TR-TG</b>	25.40	15.88	15.88	7.93	16.25	19.25	24.1	4.0	28.58	24.6	19.1	34.15	16.25	19.25	25.7	7.93	35.45
<b>DBC100 TR-TG</b>	31.75	19.05	19.05	9.54	19.75	22.85	30.1	4.5	39.69	31.8	25.4	44.50	19.75	22.85	31.0	9.54	44.0



# TopRoller Chain

## Top Roller Chain – Double Pitch Type

### Single strand

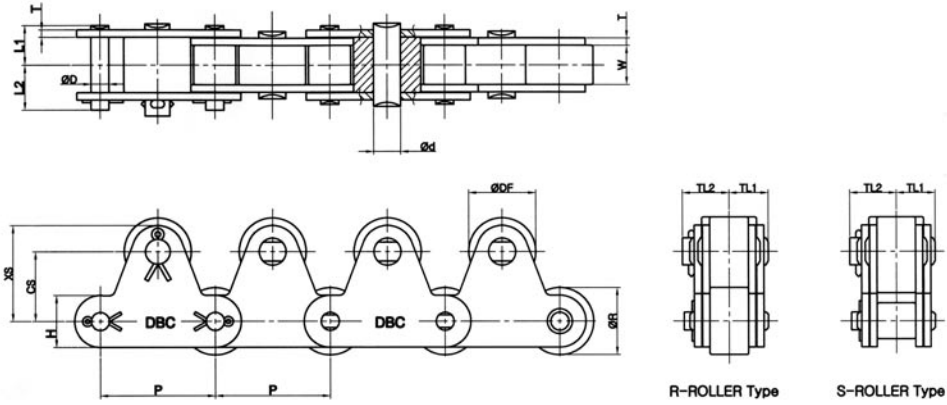

unit : mm

Dong Bo CHAIN NO.	Pitch P	Inner Width W	Roller Dia		Pin			Plate		Approx Weigth (kg/m)				
			S-Roller Type	R-Roller Type	D	L1	L1	H	T	Steel Top Roller Series		PlasticTop Roller Series		Plastic R Roller
										S-Roller Type	R-Roller Type	S-Roller Type	R-Roller Type	
<b>DBC 2040 TR</b>	25.40	7.95	7.94	15.88	3.97	8.25	9.95	12.0	1.5	1.40	1.7	0.9	1.3	0.9
<b>DBC 2050 TR</b>	31.75	9.53	10.16	19.05	5.09	10.3	12.0	15.0	2.0	2.10	2.5	1.5	1.90	1.4
<b>DBC 2060 TR</b>	38.10	12.70	11.91	22.23	5.96	14.55	16.55	18.1	3.2	3.7	4.4	2.8	3.5	2.8
<b>DBC 2080 TR</b>	50.80	15.88	15.88	28.58	7.93	18.3	20.9	24.1	4.0	5.7	6.8	4.3	5.40	4.5
<b>DBC 2100 TR</b>	63.50	19.05	19.05	39.69	9.54	21.8	24.5	30.1	4.8	9.2	11.4	6.5	8.8	6.6

unit : mm

Dong Bo CHAIN NO.	Attachment Dimensions					
	DF	CS	XS	TL1	TL2	d
<b>DBC 2040 TR</b>	15.88	15.0	21.0	8.45	10.05	3.97
<b>DBC 2050 TR</b>	19.05	19.0	26.5	10.5	12.9	5.95
<b>DBC 2060 TR</b>	22.23	23.0	31.6	14.75	17.75	7.94
<b>DBC 2080 TR</b>	28.58	29.0	40.5	18.5	21.3	11.1
<b>DBC 2100 TR</b>	39.69	35.4	49.7	22.1	27.2	11.1



## TopRoller Chain

### Top Roller Chain – Double Pitch Type

#### Double strands

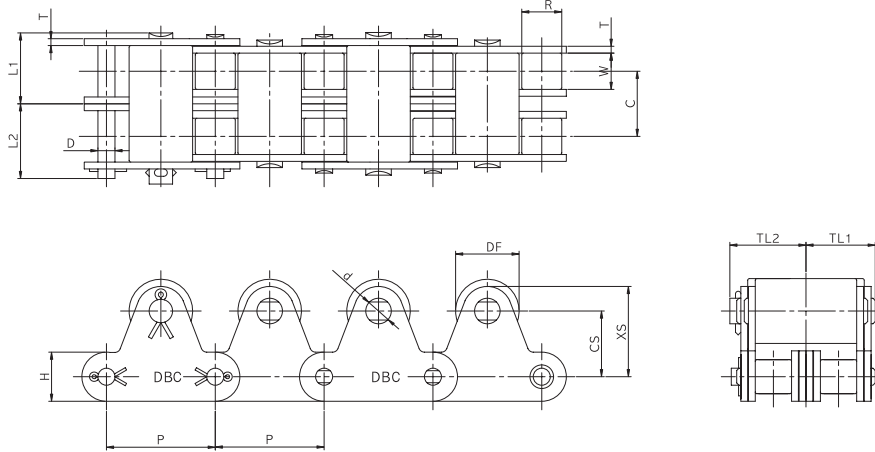

unit : mm

Dong Bo CHAIN NO.	Pitch P	Inner Width W	Transverse Pitch C	Roller Dia		Pin			Plate		Attachment Dimensions					
				S-Roller Type	R-Roller Type	D	L1	L2	H	T	DF	CS	XS	TL1	TL2	d
<b>DBC 2040-2 TR</b>	25.40	7.95	14.4	7.94	15.88	3.97	8.25	9.95	12.0	1.5	15.88	15.0	21.0	15.65	17.25	3.97
<b>DBC 2050-2 TR</b>	31.75	9.53	18.1	10.16	19.05	5.09	10.3	12.0	15.0	2.0	19.05	19.0	26.5	19.55	21.95	5.95
<b>DBC 2060-2 TR</b>	38.10	12.70	26.2	11.91	22.23	5.96	14.55	16.55	18.1	3.2	22.23	23.0	31.6	27.85	30.85	7.94
<b>DBC 2080-2 TR</b>	50.80	15.88	32.6	15.88	28.58	7.93	18.3	20.9	24.1	4.0	28.58	29.0	40.5	34.8	37.5	11.1
<b>DBC 2100-2 TR</b>	63.50	19.05	39.1	19.05	39.69	9.54	21.8	24.5	30.1	4.8	39.69	35.4	49.7	41.65	46.75	11.1

### Derailing Prevention Type

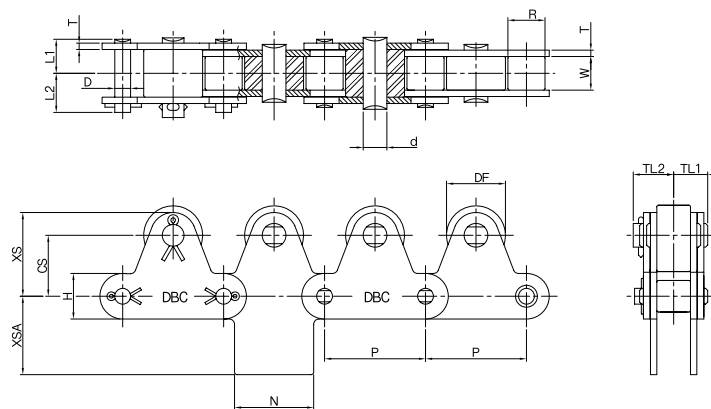

unit : mm

Dong Bo CHAIN NO.	Pitch P	Inner Width W	Roller Dia		Pin			Plate		Attachment Dimensions								
			S-Roller Type	R-Roller Type	D	L1	L2	H	T	DF	CS	XS	TL1	TL2	TL	d	N	XSA
<b>DBC 2040-2 TR</b>	25.40	7.95	7.94	15.88	3.97	8.25	9.95	12.0	1.5	15.88	15.0	21.0	8.45	10.05	13.6	3.97	19.1	12.7
<b>DBC 2050-2 TR</b>	31.75	9.53	10.16	19.05	5.09	10.3	12.0	15.0	2.0	19.05	19.0	26.5	10.5	12.9	16.6	5.95	23.8	15.9
<b>DBC 2060-2 TR</b>	38.10	12.70	11.91	22.23	5.96	14.55	16.55	18.1	3.2	22.23	23.0	31.6	14.75	17.75	22.6	7.94	28.6	19.1
<b>DBC 2080-2 TR</b>	50.80	15.88	15.88	28.58	7.93	18.3	20.9	24.1	4.0	28.58	29.0	40.5	18.15	21.25	27.8	11.1	38.1	25.4
<b>DBC 2100-2 TR</b>	63.50	19.05	19.05	39.69	9.54	21.8	24.5	30.1	4.8	39.69	35.4	49.7	22.1	27.2	34.1	11.1	47.6	31.8